

Assembly instruction

Rhombus profile

20.5 x 81 mm

Date: 02.12.2021 | EN

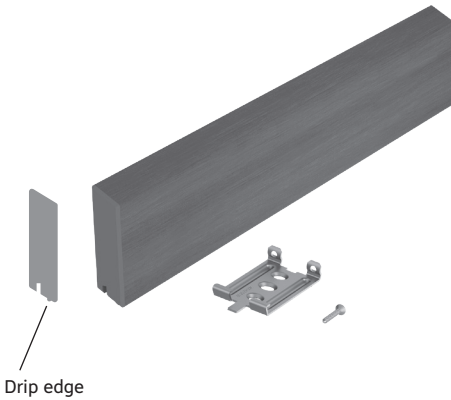

Pre-drill all holes. The screws for fastening of the rhombus profile need to be adapted according to the substructure. The frontal butt joint must be at least 8 mm.

